

Sample Form (GMAW & FCAW)
WELDING PROCEDURE SPECIFICATION (WPS)

RED Inc.
Company Name
J. Jones
Authorized by
01/18/1988
Date

2010 pg 357
WPS No.
231
Supporting PQR(s)
0
Rev. No.
12/01/1987
Date

BASE METALS	Specification	Type or Grade	AWS Group No.
Base Material	ASTM A131	A	I
Welded To	ASTM A131	A	I
Backing Material	ASTM A131	A	I
Other	-		

BASE METAL THICKNESS	As-Welded	With PWHT
CJP Groove Welds	3/4 - 1 1/2"	-
CJP Groove w/CVN	-	-
PJP Groove Welds	-	-
Fillet Welds	-	-
DIAMETER	-	-

JOINT DETAILS	
Groove Type	single V groove butt weld
Groove Angle	35° included
Root Opening	1/4"
Root Face	-
Back Gouging	none
Method	-

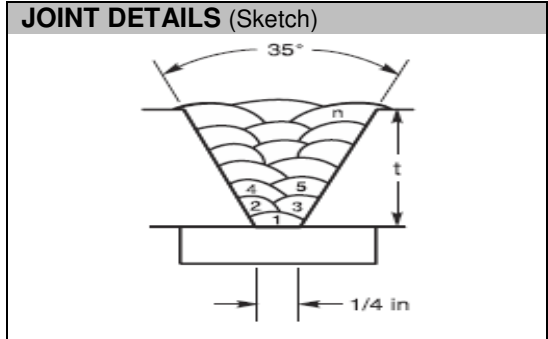

POSTWELD HEAT TREATMENT	
Temperature	None
Time at Temperature	-
Other	-

PROCEDURE									
Weld Layer(s)	All								
Weld Pass(es)	All								
Process	FCAW								
Type (Semi-Auto./Machine/Auto.)	semi-auto.								
Position	OH								
Vertical Progression	-								
Filler Metal AWS Spec.	A5.20								
AWS Classification	E71T-1								
Diameter	0.045"								
Manufacture/Trade Name	-								
Shielding Gas (Composition)	100 % CO₂								
Flow Rate	45-55 cfh								
Nozzle Size	#4								
Preheat Temperature	60° min.								
Interpass Temperature	60°-350°								
Electrical Characteristics	---								
Current Type & Polarity	DCEP								
Transfer Mode	-								
Power Source Type	-								
Amps	180 - 220								
Volts	25 - 26								
Wire Feed Speed	(Amps)								
Travel Speed	8-12 ipm								
Maximum Heat Input*	-								
Technique	---								
Stringer or Weave	stringer								
Multi or Single Pass (per side)	multipass								
Oscillation (Machine/Automatic)	-								
Number of Electrodes	1								
Contact Tube to Work Dist.	1/2-1"								
Peening	None								
Interpass Cleaning	wire brush								
Other	-								

Sample Form (GMAW & FCAW)
WELDING PROCEDURE SPECIFICATION (WPS)

RED Inc.
Company Name
J. Jones
Authorized by
01/18/1988
Date

2010 pg 357
WPS No.
231
Supporting PQR(s)
1
Rev. No.
12/01/1987
Date

BASE METALS	Specification	Type or Grade	AWS Group No.
Base Material	ASTM A131	A	I
Welded To	ASTM A131	A	I
Backing Material	ASTM A131	A	I
Other	-		

BASE METAL THICKNESS	As-Welded	With PWHT
CJP Groove Welds	3/4 - 1 1/2"	-
CJP Groove w/CVN	-	-
PJP Groove Welds	-	-
Fillet Welds	-	-
DIAMETER	-	-

JOINT DETAILS	
Groove Type	single V groove butt weld
Groove Angle	35° included
Root Opening	1/4"
Root Face	-
Back Gouging	none
Method	-

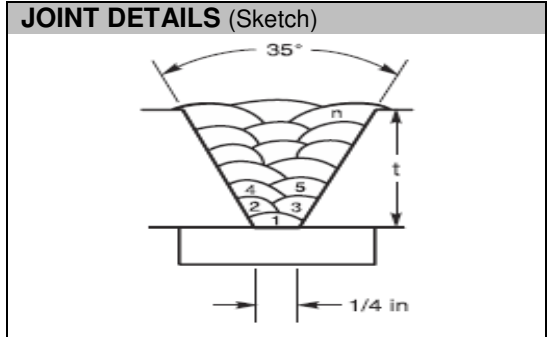

POSTWELD HEAT TREATMENT	
Temperature	None
Time at Temperature	-
Other	-

PROCEDURE	
Weld Layer(s)	All
Weld Pass(es)	All
Process	FCAW
Type (Semi-Auto./Machine/Auto.)	semi-auto.
Position	OH
Vertical Progression	-
Filler Metal AWS Spec.	A5.20
AWS Classification	E71T-1
Diameter	0.045"
Manufacture/Trade Name	-
Shielding Gas (Composition)	100 % CO ₂
Flow Rate	45-55 cfh
Nozzle Size	#4
Preheat Temperature	60° min.
Interpass Temperature	60°-350°
Electrical Characteristics	---
Current Type & Polarity	DCEP
Transfer Mode	-
Power Source Type	-
Amps	180 - 220
Volts	25 - 26
Wire Feed Speed	(Amps)
Travel Speed	8-12 ipm
Maximum Heat Input*	-
Technique	---
Stringer or Weave	stringer
Multi or Single Pass (per side)	multipass
Oscillation (Machine/Automatic)	-
Number of Electrodes	1
Contact Tube to Work Dist.	1/2-1"
Peening	None
Interpass Cleaning	wire brush
Other	-

Sample Form (GMAW & FCAW)
WELDING PROCEDURE SPECIFICATION (WPS)

RED Inc.
Company Name
J. Jones
Authorized by
01/18/1988
Date

2010 pg 357
WPS No.
2
Rev. No.
12/01/1987
Date
231
Supporting PQR(s)

BASE METALS	Specification	Type or Grade	AWS Group No.
Base Material	ASTM A131	A	I
Welded To	ASTM A131	A	I
Backing Material	ASTM A131	A	I
Other	-		

BASE METAL THICKNESS	As-Welded	With PWHT
CJP Groove Welds	3/4 - 1 1/2"	-
CJP Groove w/CVN	-	-
PJP Groove Welds	-	-
Fillet Welds	-	-
DIAMETER	-	-

JOINT DETAILS	
Groove Type	single V groove butt weld
Groove Angle	35° included
Root Opening	1/4"
Root Face	-
Back Gouging	none
Method	-

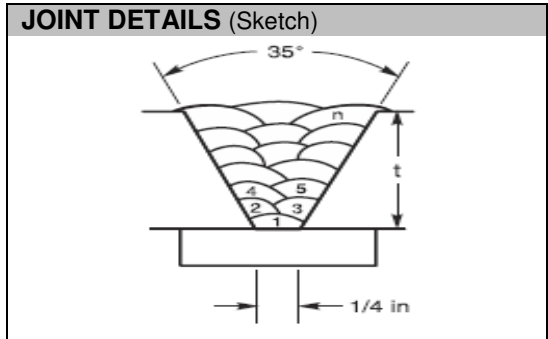

POSTWELD HEAT TREATMENT	
Temperature	None
Time at Temperature	-
Other	-

PROCEDURE	
Weld Layer(s)	All
Weld Pass(es)	All
Process	FCAW
Type (Semi-Auto./Machine/Auto.)	semi-auto.
Position	OH
Vertical Progression	-
Filler Metal AWS Spec.	A5.20
AWS Classification	E71T-1
Diameter	0.045"
Manufacture/Trade Name	-
Shielding Gas (Composition)	100 % CO ₂
Flow Rate	45-55 cfh
Nozzle Size	#4
Preheat Temperature	60° min.
Interpass Temperature	60°-350°
Electrical Characteristics	---
Current Type & Polarity	DCEP
Transfer Mode	-
Power Source Type	-
Amps	180 - 220
Volts	25 - 26
Wire Feed Speed	(Amps)
Travel Speed	8-12 ipm
Maximum Heat Input*	-
Technique	---
Stringer or Weave	stringer
Multi or Single Pass (per side)	multipass
Oscillation (Machine/Automatic)	-
Number of Electrodes	1
Contact Tube to Work Dist.	1/2-1"
Peening	None
Interpass Cleaning	wire brush
Other	-

(see aws.org/forms for more examples)